

# SPORTSMAN® POLARIS® PRO HD WINCH KIT



**P/N 2882242**

## APPLICATION

Verify accessory fitment at [Polaris.com](http://Polaris.com).

## BEFORE YOU BEGIN

Read these instructions and check to be sure all parts and tools are accounted for. Please retain these installation instructions for future reference and parts ordering information.

## KIT CONTENTS

This Kit includes:

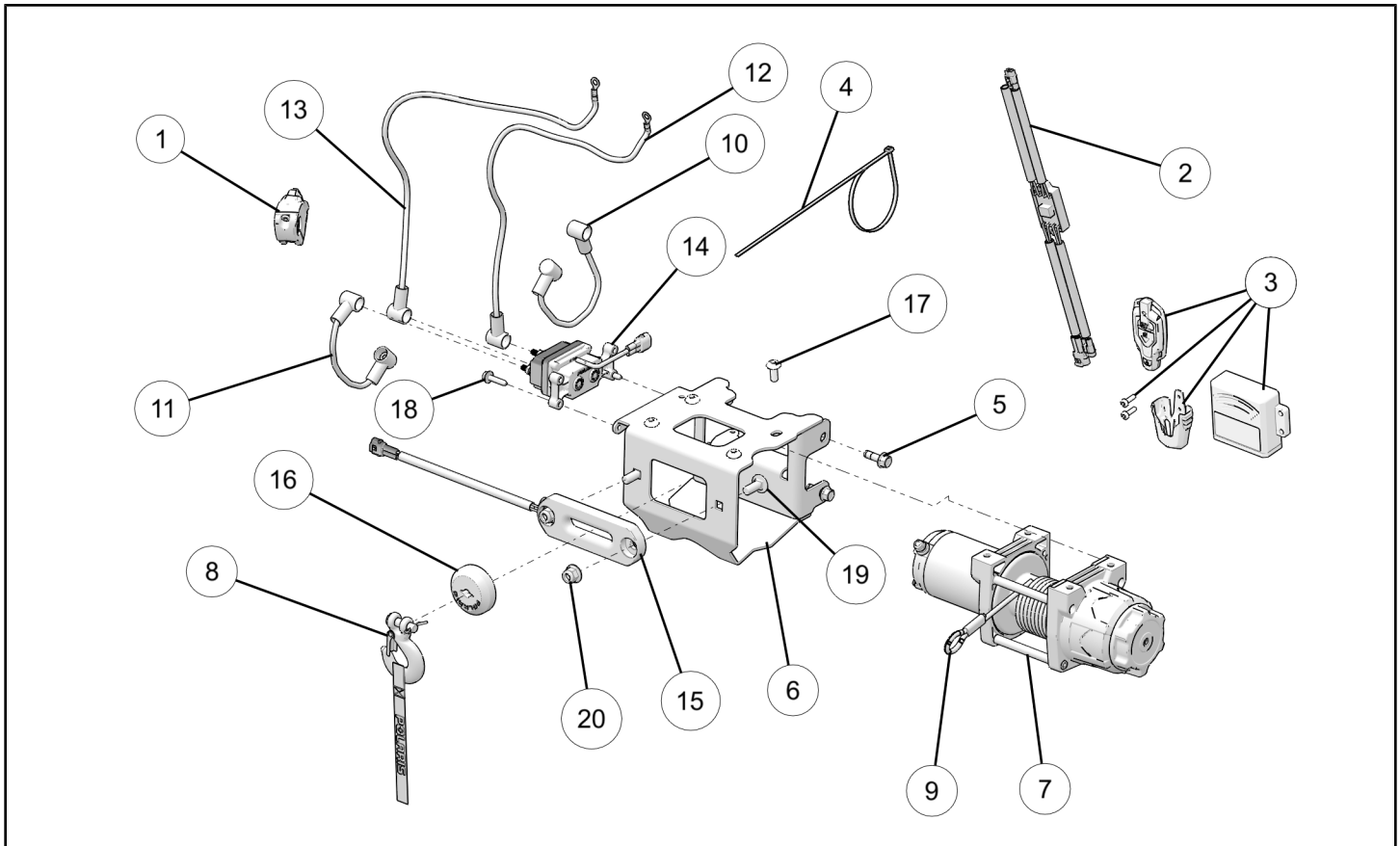

REF	QTY	PART DESCRIPTION	PART NUMBER
1	1	Handlebar Switch	2205636
2	1	Control Box	2413444
3	1	Wireless Remote Kit	2879316
4*	5	Cable Ties, Nylon	-
5*	4	Screw, Hex Flange - M8 X 1.25 X 25	-
6	1	Mounting Bracket	1022577
7	1	Winch - 3500 HDDS	2206383
8	1	Hook, Winch Latch	2411836

REF	QTY	PART DESCRIPTION	PART NUMBER
9	1	Rope	2878888
10	1	Winch Cable, Yellow 6 GA (mm)	4013468-300
11	1	Winch Cable, Blue 6 GA (mm)	4013469-300
12	1	Power Cable, Black #6 (mm)	4013470-530
13	1	Power Cable, Red #6 (mm)	4013471-510 WC
14	1	Contactor	4015095
15	1	Autostop Fairlead	5140385
16	1	Stop Magnet	5415787
17	4	Screw Torx®Head - M8 X 1.25 X 20	-
18*	2	Screw - M6 X 1.0 X 25	-
19*	2	Screw - M10 X 1.5 X 25	-
20*	2	Nut - M10 X 1.5	-
	1	Winching Guide	9923644
	1	Instructions	9927475
		Service Handle (includes freespool handle and screw)	2205265

Items marked (\*) are included in Hardware Kit (PN 2880643).

## TOOLS REQUIRED

- Safety Glasses
- Socket Set, Metric
- Screwdriver, Phillips
- Wire Cutter
- Hex Key Set, Metric
- Socket Set, Torx® Bit

## IMPORTANT

Your SPORTSMAN® POLARIS® PRO HD WINCH KIT is exclusively designed for your vehicle. Please read the installation instructions thoroughly before beginning. Installation is easier if the vehicle is clean and free of debris. For your safety, and to ensure a satisfactory installation, perform all installation steps correctly in the sequence shown.

## ASSEMBLY TIME

Approximately 40 minutes

# INSTALLATION INSTRUCTIONS

## NOTE

This kit contains the same components as Sportsman (XP) winch kit (PN 2882241), but have been pre-assembled differently. If you need to install this kit on a Sportsman (XP) vehicle, refer to image below that shows the contactor location and wire routing for Sportsman (XP) winch kit, and reassemble the contactor and wiring to match below image. You will need to download instructions manual (PN 9927474) and follow those instructions for final installation.

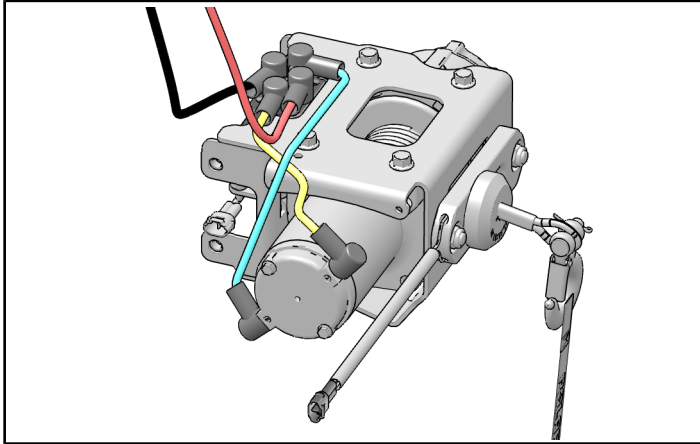

\* ABOVE IMAGE REFERS TO KIT PN 2882241

## PREPARATION

1. Place vehicle in "PARK". Turn key to "OFF" position and remove from vehicle.
2. Detach the rubber latch (B) on both sides to open front rack (A).

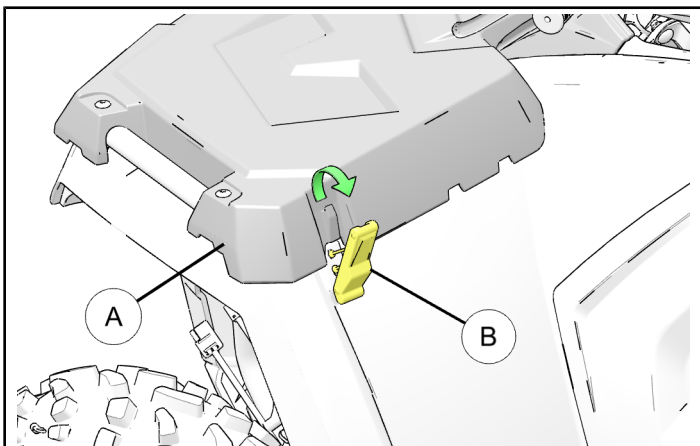

3. Open the front rack (A) and remove rubber seal (C).

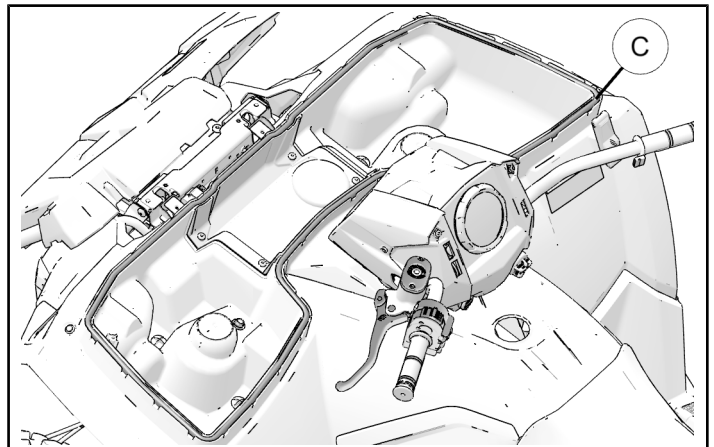
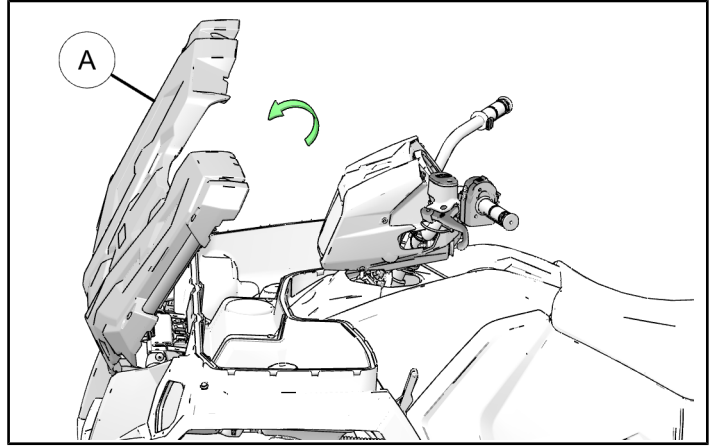

4. Remove four screws (D) holding front cover (E) in place. Retain the screws (D) for reinstallation.

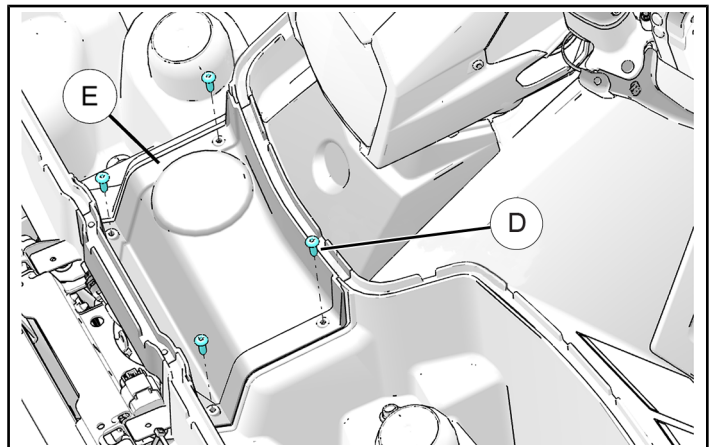

5. Lift the front cover (E) upwards slowly to disengage the tabs on front cover from the slots (F) as shown.

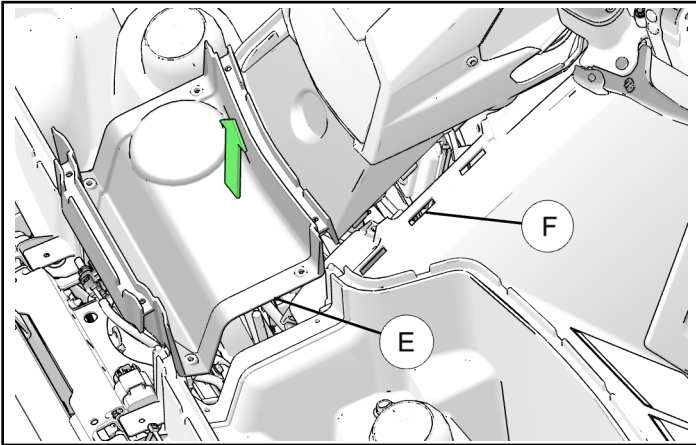

6. Disconnect black (negative) and red (positive) cables from battery.

**⚠ WARNING**

**ALWAYS** disconnect black negative (-) cable from battery **FIRST**. Failure to do so will result in high current electrical arc, and may result in battery explosion if tool touches grounded frame. Death or serious personal injury may occur.

7. Disconnect the black (negative) (H) and red (positive) (G) cables from the bus bar.

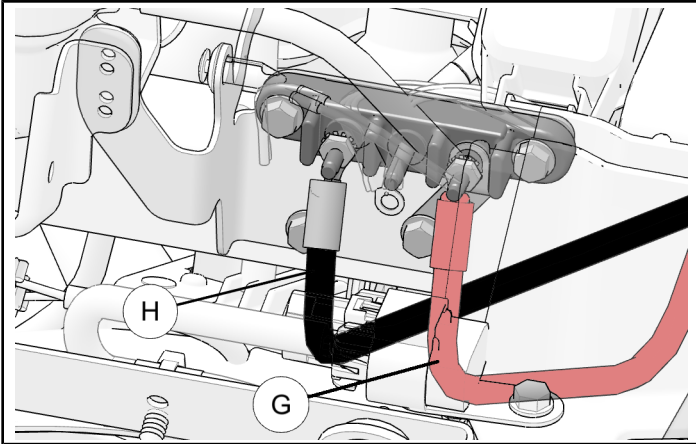

8. Remove the accessory front brushguard from vehicle (if equipped).

9. Remove lower front bumper cover (J) from vehicle by removing four bolts (K) as shown. Retain bolts for use during reinstallation.

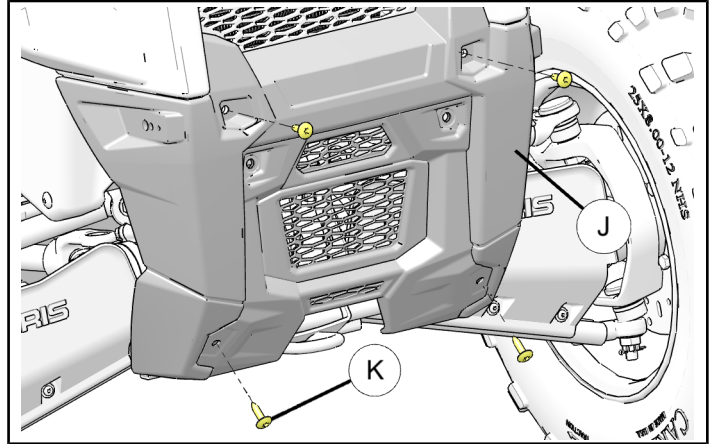

10. Remove winch cover (L) from the lower front bumper cover (J). If you plan to use a plow, remove winch cover from the lower front bumper cover (J) and do not reinstall. If you do not plan to use a plow on your vehicle, cut out the center section as shown and reinstall winch cover on the lower front bumper cover if you desire, but it is not required.

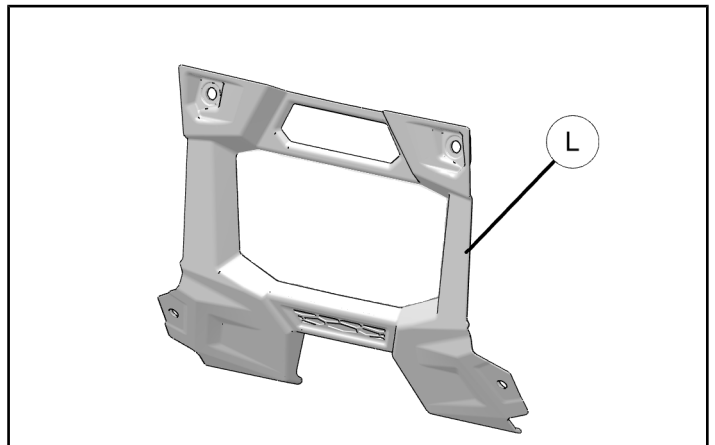
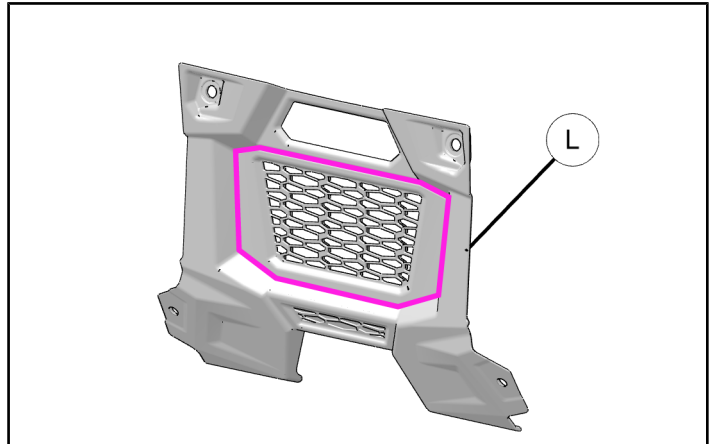

### NOTE

Before installing the winch kit add or replace the proper fluid to your front gearcase as required per your vehicles service manual as this process will be difficult to do after the winch is installed.

## WINCH INSTALLATION

### NOTE

See the Electrical Connections Reference Guide section of the instruction manual for detailed photos of each part and their respective connections.

1. Check and confirm wire routing and connections are as shown below and make necessary adjustment before moving to next installation steps.

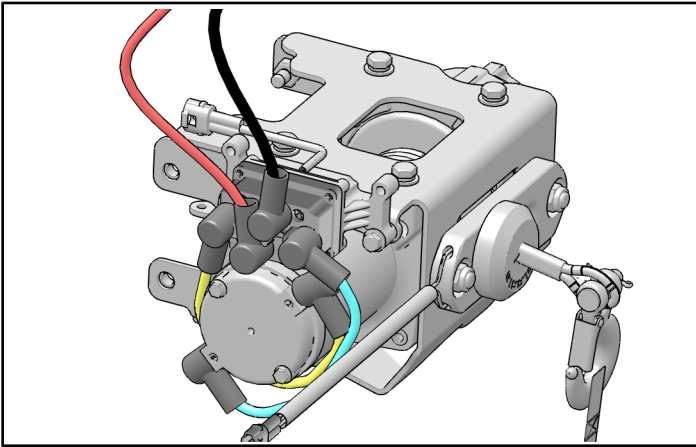

### NOTE

If you have a Utility model, the brackets supporting the front steel bumper will interfere with the blue and yellow wires in the stock configuration as seen above. You will need to loosen the nuts holding the blue and yellow wires to the contactor, rotate them as shown below, and then re-tighten the nuts. Refer to image below for proper routing.

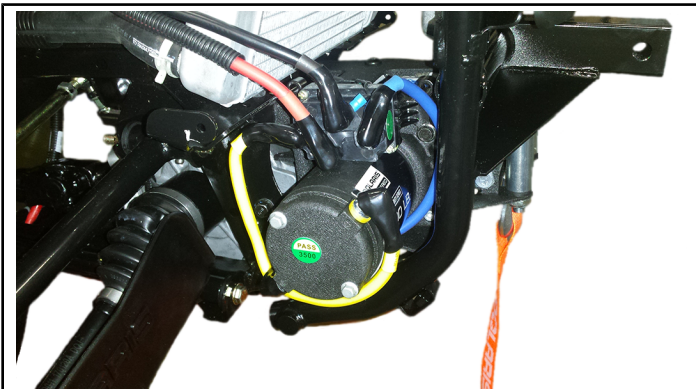

2. Locate white contactor connection (M) on winch assembly. If it is secured to the winch assembly with a plastic tie, cut the tie to allow the wires to be routed properly.

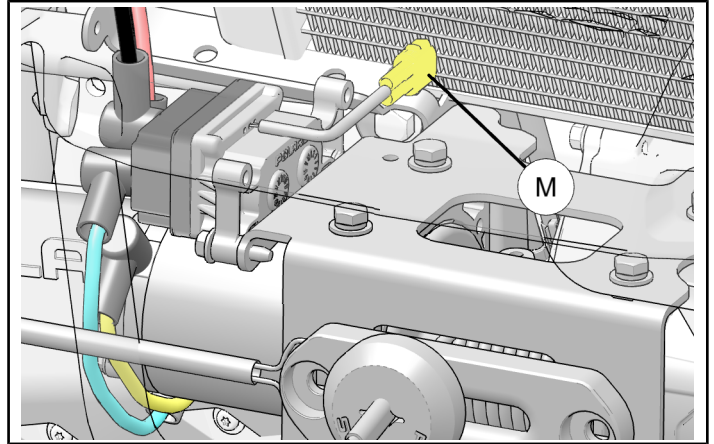

3. Install winch assembly (7) onto the radiator mount (N) with the supplied four screws (5). Check that all wires are free to move and not pinched between the vehicle chassis and the winch assembly. Torque screws to below specification.

### TORQUE

20 ft. lbs. (27.1 Nm)

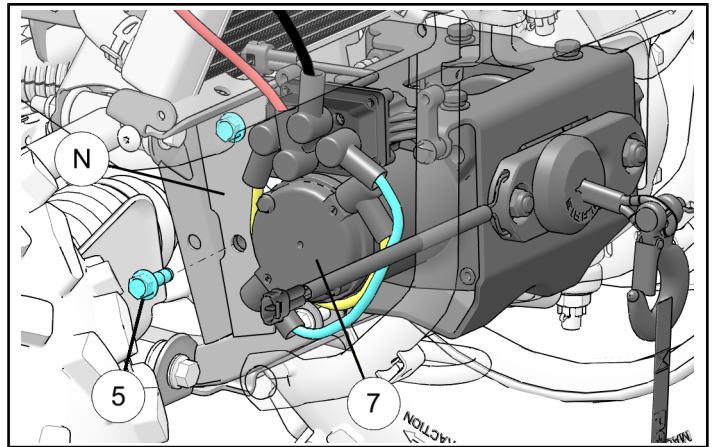

- Route red (positive) ⑬ and black (negative) ⑫ winch cables on the side of the radiator then behind it to reach the three terminal bus bar as shown. **DO NOT CONNECT TO THE WINCH CABLES TO THE BUS BAR AT THIS TIME.**

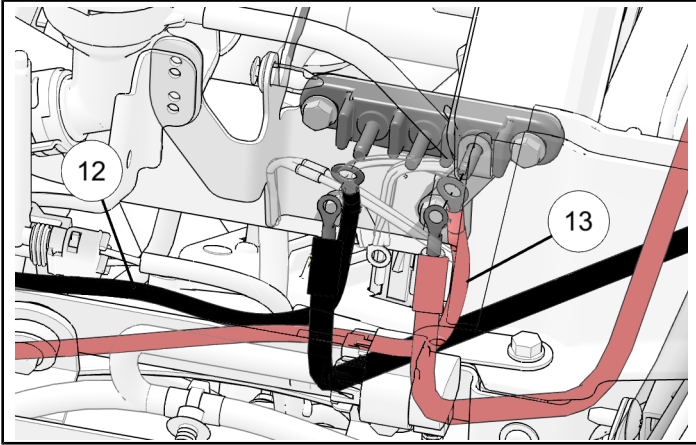

### CONTROL BOX INSTALLATION

- Position control box ② on the right side of the vehicle behind the radiator as seen in the photo below. Connect white electrical connectors for the control box as seen in the top photo of the Electrical Connections Reference Guide section of the instruction manual.



- Route power wires to battery area and connect red or orange wire from control box to orange wire on the vehicle's main wire harness as seen below. Route black wires from control box ② to black (ground) terminal area near the bus bar. **DO NOT CONNECT TO THE BUS BAR AT THIS TIME.**

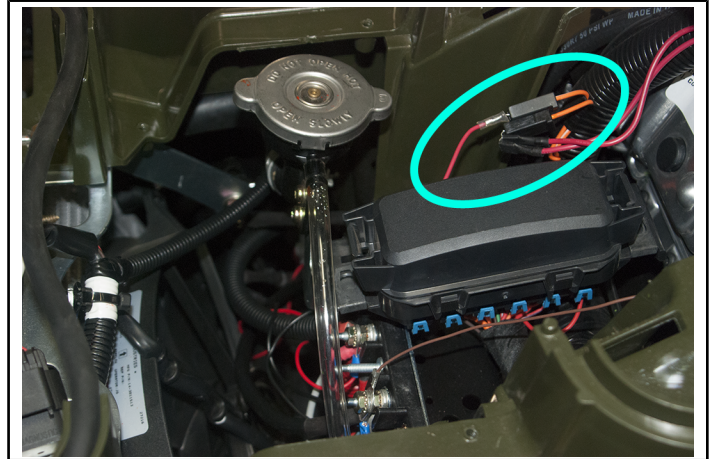

### WIRELESS REMOTE RECEIVER INSTALLATION

- Install wireless remote box ③ onto cab support bracket ① using cable ties as shown.

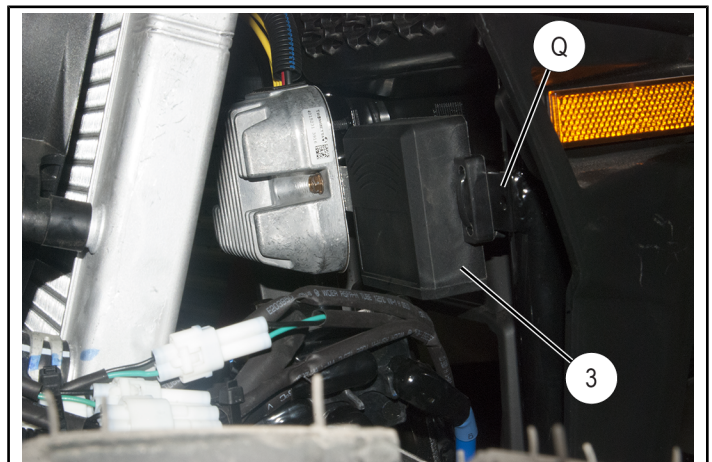
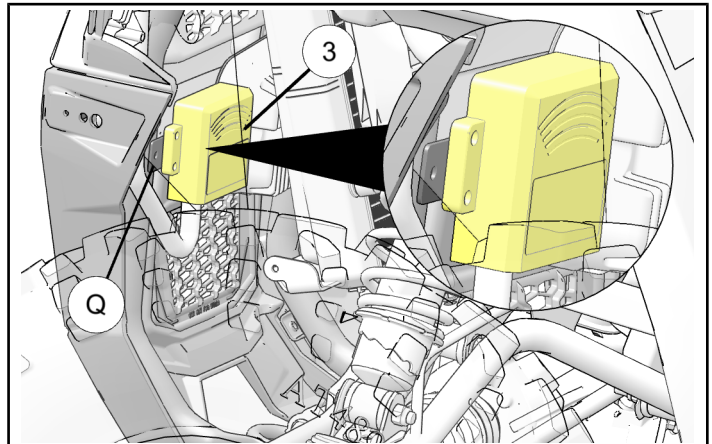

2. Connect white electrical connectors as seen in the top photo of the Electrical Connections Reference Guide. Route power wires to battery area and connect red or orange wire on control box to orange wire on vehicle main wire harness as seen below. Route black wires from control box ② to black (ground) terminal area on bus bar.

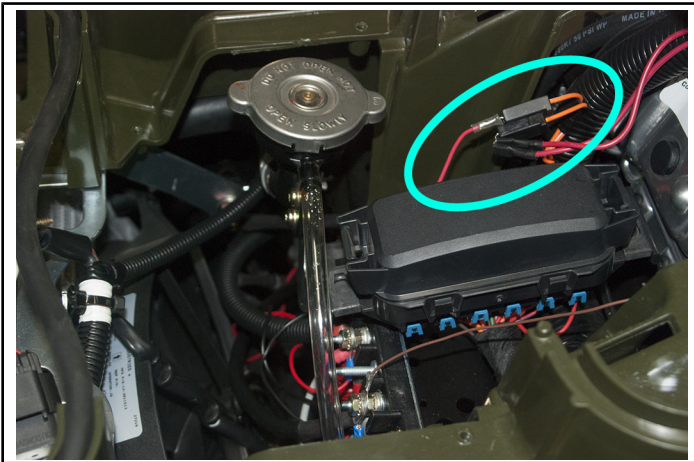

3. Now connect the red ⑥ and black ⑧ wires to the bus bar terminals along with winch power cables ⑬ ⑭ using existing fasteners ①. Also, connect black wires on the wireless remote receiver box ③ and control box ② to battery negative (ground) terminal at this time.

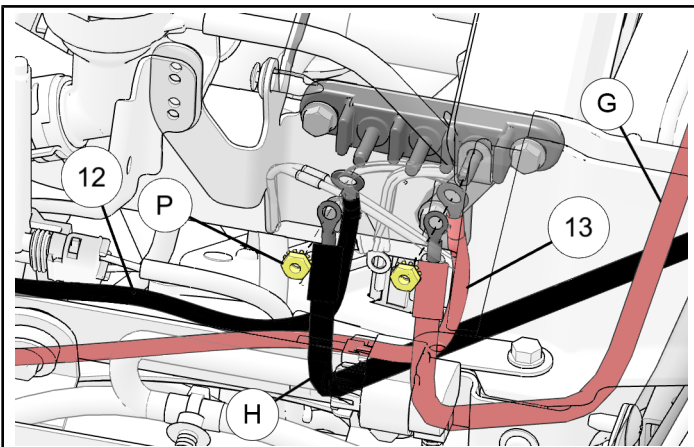

4. Secure all remaining wires to vehicle main wire harness using cable ties as shown.



## HANDLEBAR SWITCH INSTALLATION

1. Install the handlebar switch ① using the supplied screws ② onto handlebar as shown. Torque screws to the specification listed below being careful not to overtighten.

### TORQUE

2 ft. lbs. (2.7 Nm)

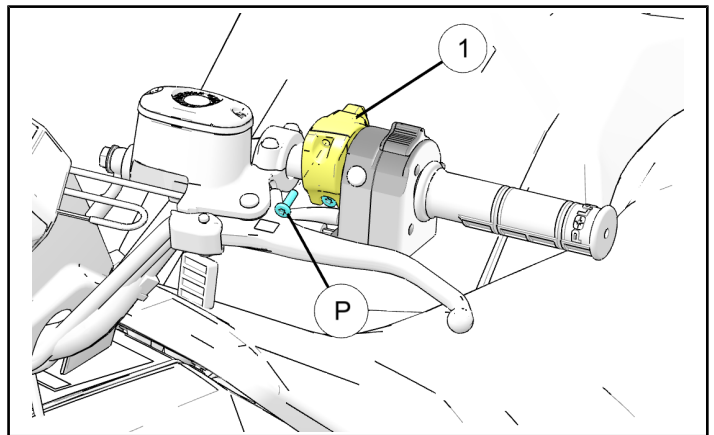

2. Connect handlebar switch connector ③ to the vehicle main wire harness as shown.

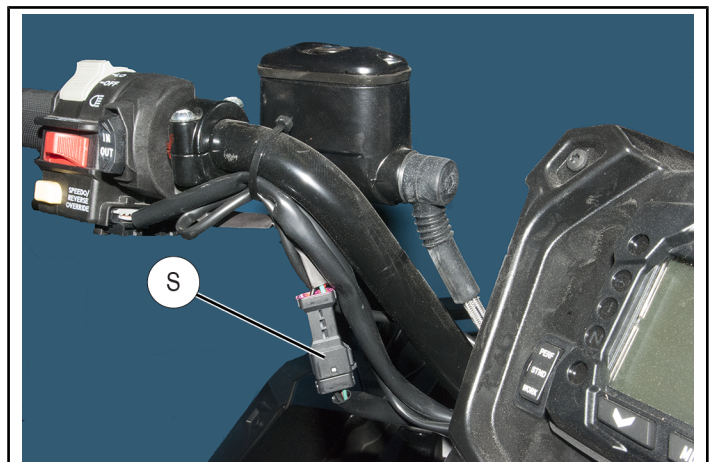

## WIRELESS REMOTE HOLDER INSTALLATION

1. Wireless remote holder can be installed in desired location on vehicle. Use the screws provided in the wireless remote kit for holder installation. For your reference see the photo below for possible mounting location of wireless remote holder.



## FINAL INSPECTION

1. Confirm that all wiring is correct.
2. Confirm that there are no exposed wires or terminals.
3. All loose wires need to be wrapped tight, and secured away from moving parts and heat sources.

## REINSTALLATION

1. Reinstall the lower front bumper cover (J). If you plan to use a plow, do not reinstall winch cover (L). If you do not plan to use a plow, reinstall winch cover (L).

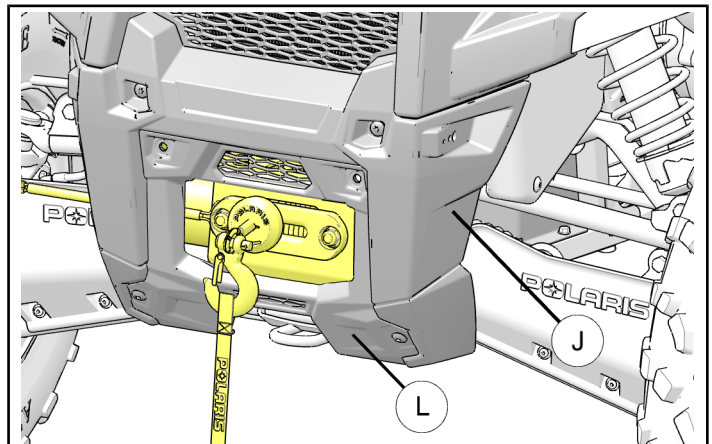
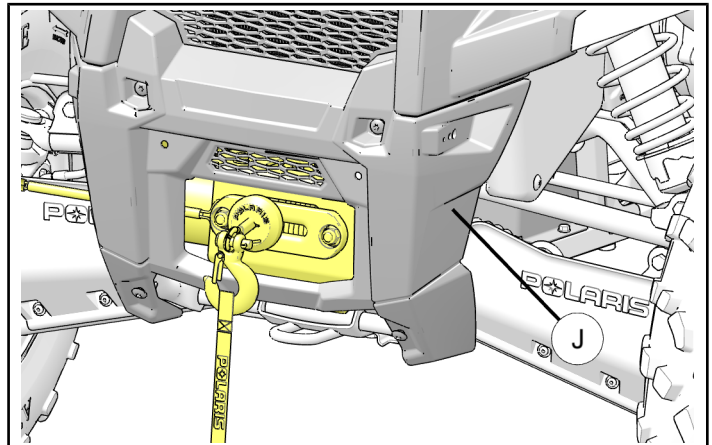

2. Reinstall accessory front brushguard (if equipped).
3. Reconnect battery red (positive) and black (negative) cables to battery terminals at this time.
4. Reinstall the front cover (E) using retained screws (D).
5. Close the front rack (A) and secure in place using rubber latches (B).
6. With the vehicle key in the ON position, check winch for proper operation.

Test function of Autostop feature. When reeling in the winch rope, confirm that the winch will turn off automatically when the rubber puck reaches the aluminum fairlead. The winch should not allow the rope to be reeled in once the rubber puck has come within a close proximity (typically 1" or less) or made contact to the fairlead. If the Autostop is not functioning properly, see troubleshooting information at the end of the instructions.



## HANDLEBAR SWITCH OPERATION

- When properly installed, the handlebar switch allows you to operate the winch while seated on the vehicle. See the illustration below for proper switch operation.

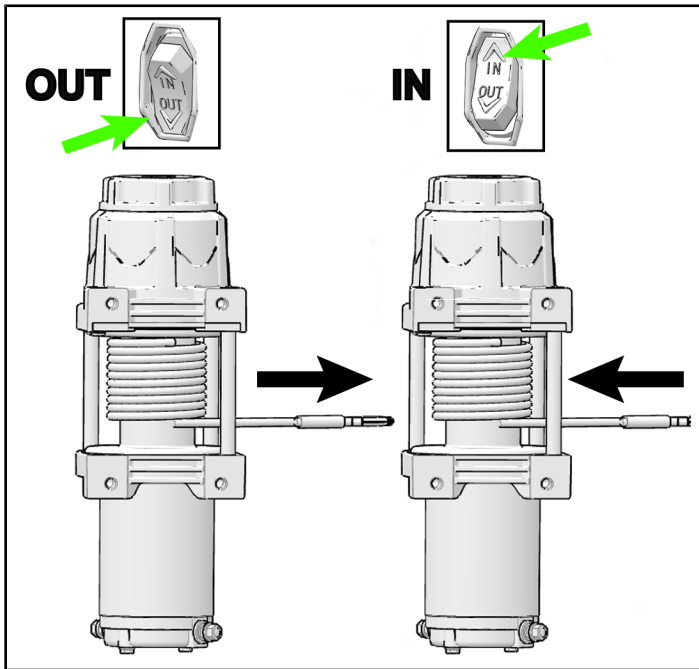

## WIRELESS REMOTE OPERATION

- When properly installed, the wireless remote will allow you to operate the winch from off the vehicle, which can be a safe way to operate the winch when done properly.
- To use the wireless remote, hold the small "On/Off" button for three seconds or until the LED light on the remote turns on. If the vehicle is on so that the winch is receiving power, the wireless remote should operate the winch as if you were using the winch switch ① located on the handlebar. If the remote is not operating properly, see the troubleshooting information at the end of the instructions.
- The remote will automatically turn itself off after 30 seconds of inactivity. You will therefore need to turn the remote back on if it has been more than 30 seconds since prior use.
- To manually turn off the remote, hold the small "On/Off" button for 3 seconds or until the LED light turns off.
- See the illustration below for proper wireless remote operation.

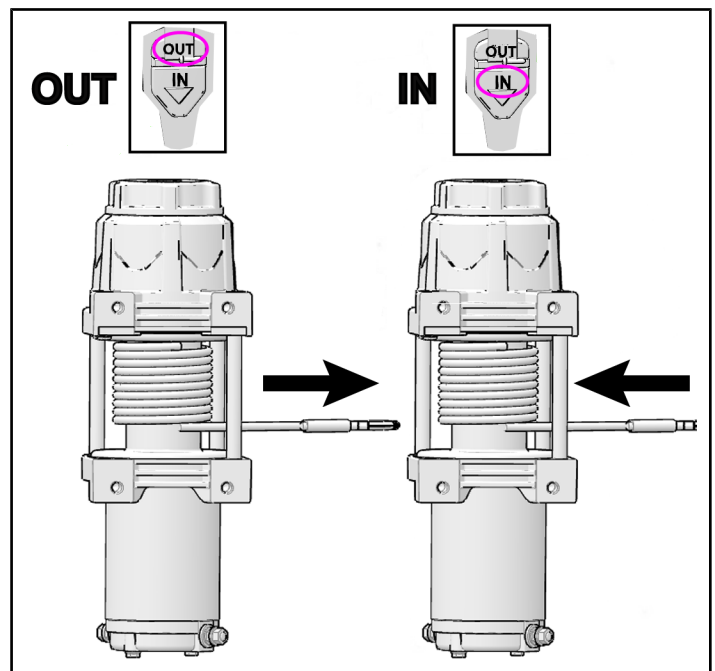

## AUTOSTOP OPERATION

The Autostop system is meant to help prevent damage to the winch system from over-tightening of the rope, but is not meant to prevent all foreseeable winch damage. The winch is very powerful and care should be exercised whenever it is in operation. The winch operator is always responsible for using the winch properly and the Autostop system should only be used as a secondary preventive measure to help prevent damage to the winch from over-tightening the rope.

The Autostop system works when the black rubber puck nears the aluminum fairlead ⑮. Stop magnets ⑯ in the puck trigger sensors in the fairlead, which prevent the contactor from pulling in the winch rope any further.

During final inspection, confirm that the Autostop is functioning properly. Troubleshooting steps are given in that section to help diagnose and correct any problems.

## GEAR SELECTION

### WARNING

Attempting to shift the winch while the rope is under tension is dangerous and can result in injuries or death. Make sure the winch rope is not in tension before shifting the winch between gears.

Your winch is equipped with three different gear settings. High, Neutral and Low. When in neutral the “N” marking will show thru the cutout window on the shift knob. See photo below.

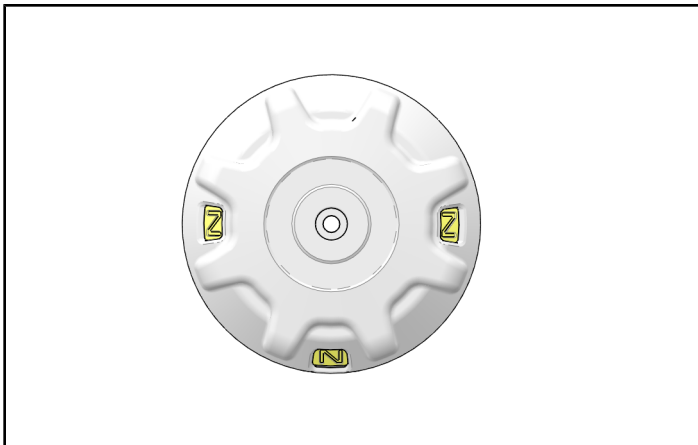

The high gear setting is meant for rapid recovery mode only and should not be used while the rope is under load. To shift into high gear, rotate the gear shifting knob clockwise until the “H” marking shows thru the cutout window on the shift knob. See photo below.

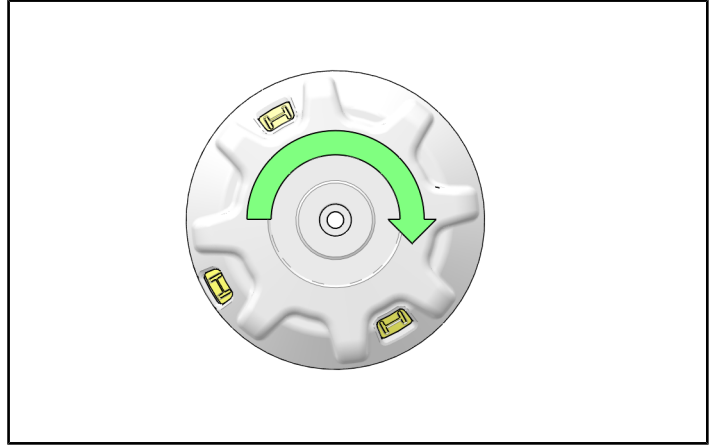

### NOTE

High gear is for rapid recovery of the winch rope only. It is not intended for pulling and will reduce the life of the winch if used under load.

To shift into low, rotate the gear shifting knob counter-clockwise until the “L” marking shows thru the cutout window on the shift knob. See photo below.

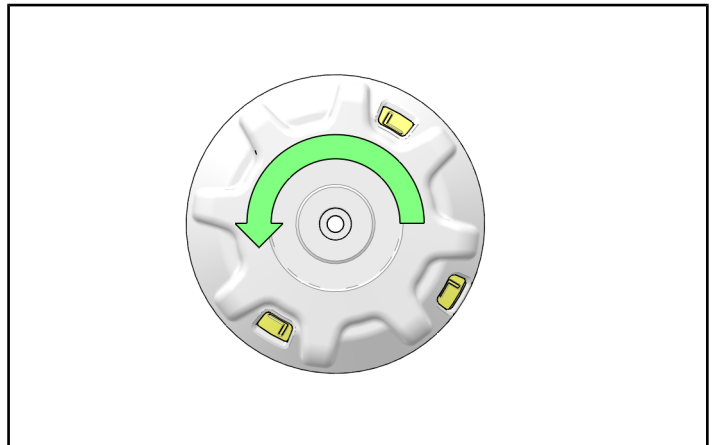

## RAPID RECOVERY WINCH FUNCTION

Your winch is equipped to quickly reel in the winch rope when being used under no-load conditions. Using this feature will significantly reduce the time it takes to rewind your rope after use.

### When to use

Use Rapid Recovery to quickly reel the rope in or out to speed up the recovery process. The rope speed is approximately five times the speed of standard operation, so caution should be taken to always reset the winch to “Low” gear after using the Rapid Recovery so the speed of the winch will not take the operator by surprise. Do not pull loads while in Rapid Recovery gear.

### How to shift

To operate the Rapid Recovery, make sure the winch is not in operation and the rope is not in tension. Rotate the shift knob fully clockwise to engage “High” gear (Rapid Recovery). Pulling slightly on the winch rope by hand will help the gears align and the shift to be completed. Use Rapid Recovery only to reel in the rope with “No Load”, then rotate the shift knob back to “Low” gear (standard operating mode) by rotating the knob back fully counter-clockwise.

### WARNING

Attempting to shift the winch while the rope is under tension is dangerous and can result in injuries or death. Make sure the winch rope is not in tension before shifting the winch between gears.

## TROUBLESHOOTING

If your winch/Autostop is not functioning properly, below is a short guide that can help you diagnose and correct the problem.

SYMPTOM	POSSIBLE CAUSES	RECOMMENDED SOLUTION
Dead Vehicle Battery	Check to ensure that both the wireless remote receiver and control box power wires are connected to keyed power and not directly to the positive battery terminal.	Rewire to ensure wiring is connected properly per instructions.
Winch will not operate	Contactors not receiving power	Turn vehicle key on.
	Wireless remote not powered on	Turn wireless remote on.
	Connections between components not in proper order	Check connections. Connect wired handlebar switch connection from vehicle main wire harness directly to contactor to make sure a direct connection will operate the winch. If connections are not in the order shown on the pictures in the last page, the whole system may not function or only certain parts of it will function.
Winch operates in one direction only	Keyed power circuit (orange wires) not properly powered	Check fusebox for 10A accessory circuit. Check voltage in certain places, especially orange wires coming out of the main harness by the steering post.
	Autostop fairlead not connected properly	Check connections. If winch operates only outward, check that the black rubber puck is not touching the aluminum fairlead. If winch operates inward even when puck is touching fairlead, check connections of the Autostop control box. If winch operates inward but not outward when rubber puck is

SYMPTOM	POSSIBLE CAUSES	RECOMMENDED SOLUTION
		touching fairlead, check color of wires at connectors to make sure they match on both sides of the connection (in case two wires have been switched in the connector).
Winch makes noise but rope does not move	Contactor powered, but not winch	If you can hear a clicking sound when you press the winch control but the winch does not make any sounds, check the connections between the winch and the contactor. If the winch makes noise but does not move, check that the winch is in gear. If the winch is in gear and the winch does not move, have a dealer inspect the winch.
Winch makes noise but rope does not move	Winch not in proper gear	Rotate gear knob fully into L or H, then recheck.
Winch operates too slowly	Winch in wrong gear	Rotate gear knob into proper gear, then recheck.
	Winch improperly loaded	The winch operates slowly in Low gear. In High (Rapid Recovery), the winch operates quickly but can be slowed if there is a load on the rope or if the rope is bound up inside the spool area. Check that the winch is clear and the rope is not bound up and that there is no load pulling on the rope.
Winch will not change gears	Rope is still under load	The gears are purposely hard to shift when a load is on the rope to prevent accidental operation, which could lead to winch failure or personal injury. Make sure the rope has no load in tension, then check that the rope is not bunched up and bound inside the spool area. Operate the winch for a short period, then attempt to shift again.

# ELECTRICAL CONNECTION REFERENCE GUIDE

## Winch with auto fairlead, wireless remote, and handle bar switch

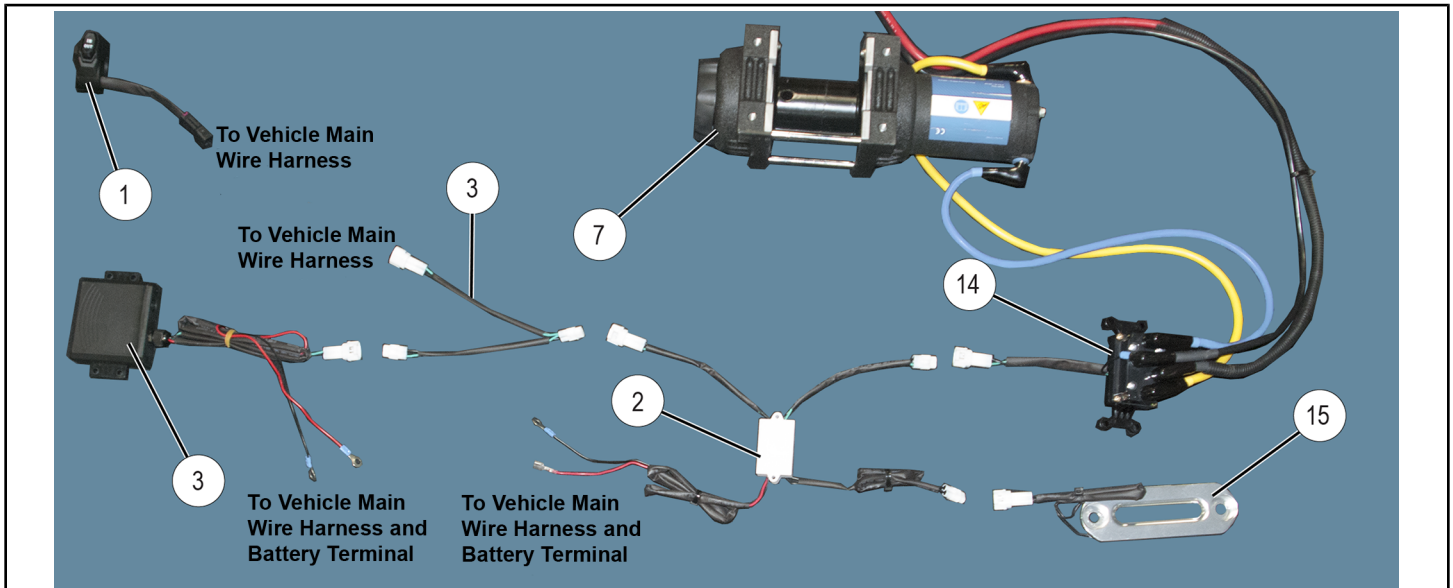

## Winch with auto fairlead and handle bar switch

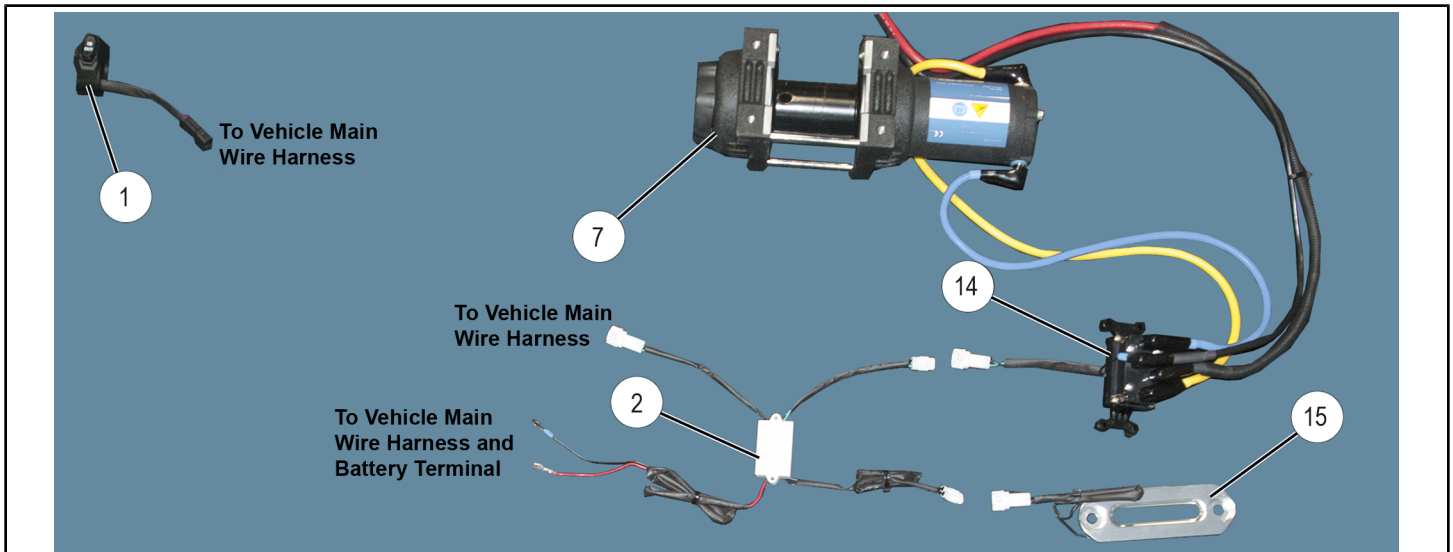

## Winch with roller fairlead and handle bar switch

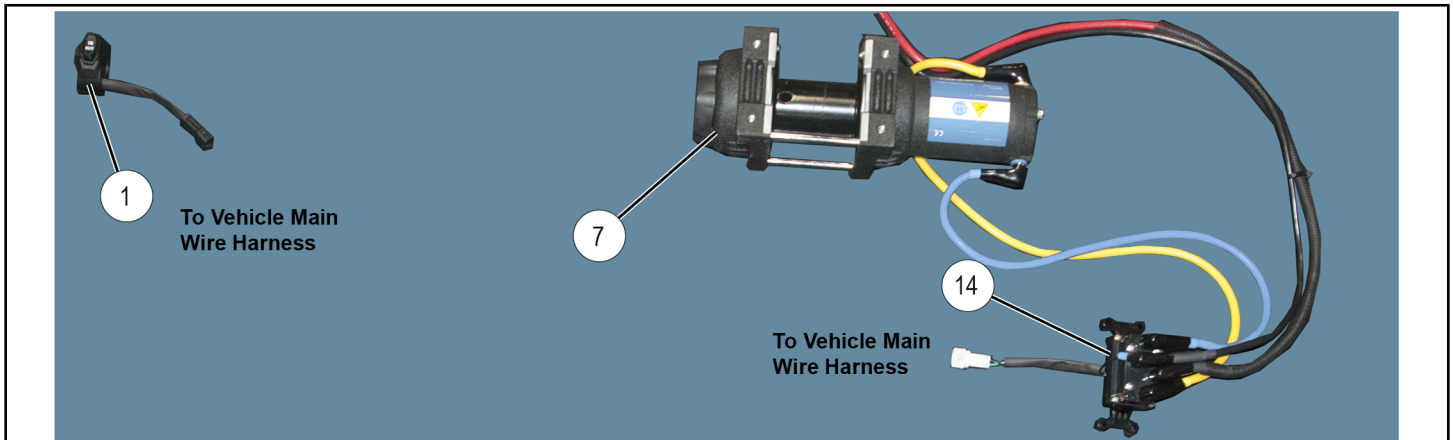

## 9927475 FEEDBACK FORM

A feedback form has been created for the installer to provide any comments, questions or concerns about the installation instructions. The form is viewable on mobile devices by scanning the QR code or by clicking [HERE](#) if viewing on a PC.

